

Rota-Loo 950 Installation Manual

*This Manual should be read in conjunction
with the
ROTA-LOO OPERATIONS MANUAL*

*If you have any queries please contact your
Rota-Loo supplier or Kiel Industries Pty
Ltd*



	<p><i>AS/NZS 1546.2:2008 is the Standard that sets out the requirements for the design and performance of Waterless Composting Toilets to assure of safe, effective and efficient operation.</i></p> <p><i>Authorities regulating the installation of Waterless Composting Toilets (local Councils etc) require Certification to the Standard to approve the installation of a system like Rota-Loo</i></p>
---	---

Address: 87-93 Tramway Road, Morwell,
VICTORIA 3840

Phone: (03) 5135 3900

Fax: (03) 5135 3955

enquiry@rotaloo.com
admin@kielindustries.com.au

www.rotaloo.com

<p>Proudly Made in Australia by Kiel Industries Pty Ltd</p> <p>A Quality Company</p> 	 www.kielindustries.com.au
---	---

QUICK GUIDE

INSTALLATION PLANNING

It's all in the planning!

For proper operation of the Rota-Loo you should consider a number of issues during the building design stages to enable the natural composting processes the best chance to give trouble-free operation.

The design of the site and building needs to allow for:

- The location of the toilet pedestal in the building and any structures that may be required to have the Rota-Loo below floor level.
- Space for the Rota-Loo and a firm, dry and sheltered base for it to sit.
- Adequate access to service and maintain the Rota-Loo.
- Warmth to assist the composting process by locating the Rota-Loo in a sunny place and maybe installing insulation, particularly in cooler climates
- Good ventilation to provide oxygen and evaporate liquids
- Electrical supply (240VAC or 12VDC) to the fan location

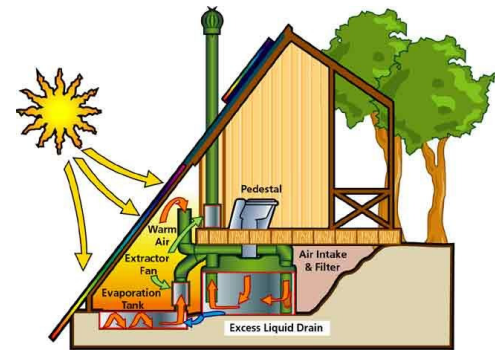

NOTE: The Rota-Loo is not designed for handling bathroom, kitchen and laundry wastes. A separate Grey Water system will be required for these wastes from your building

PLEASE READ Pages 2-4 OF THIS MANUAL DURING THE PLANNING FOR INSTALLATION OF A ROTA-LOO

INSTALLATION

The Rota-Loo RL950 is supplied as a kit containing most of the components required and can be installed using basic building tools and materials available at plumbing suppliers or hardware shops

See the Appendix (page 10) for a list of supplied parts and required materials and tools.

Installation of the Rota-Loo involves:

- Positioning the Pedestal and Rota-Loo to ensure a vertical drop from the pedestal to the waste bins
- Preparing a flat, level and firm base for the Rota-Loo to sit
- Installing the ventilation pipe-work, including vent pods, inlet, fan and Turbo Vent
- Connecting the Pedestal, waste chute and Rota-Loo
- Final checks before use.

Installation should be by a competent person(s) who is experienced with at least basic building and plumbing skills.

Setting out the site and ensuring the components are installed correctly is essential for proper operations and validation of the warranty.

Most problems with the operation of a Rota-Loo are a result of poor or incorrect installation so you should be careful to read and follow all the installation instructions.

PLEASE READ ALL INSTRUCTIONS (Pages 5-9) BEFORE STARTING

INSTALLATION PLANNING

Space Required

There is no ideal set of measurements which will suit all applications but you do need to provide enough space to locate and install the Rota-Loo, enough space to fit and maintain the air vent piping and fan and enough space to access the door to the bins. Remember that you will be accessing the bins at approximately 8 week intervals so allow space to get to the latches and manoeuvre the bins.

You will need enough space to:

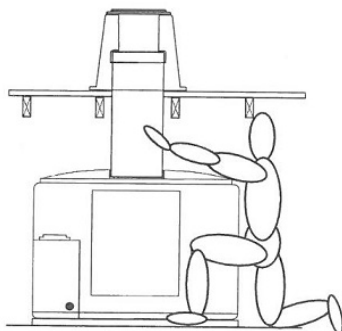
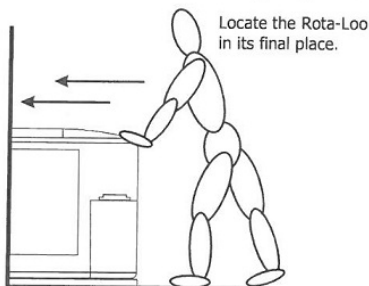

Enough space above the Rota-Loo to connect the Waste Chute.

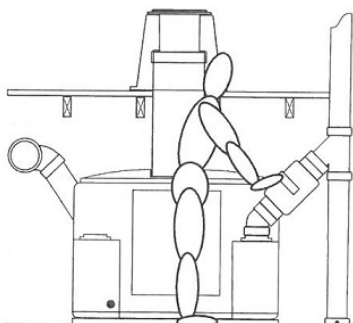

Enough space around the Rota-Loo to connect the Air Inlet, Vent pipe and to maintain the Rota-Loo once installed.

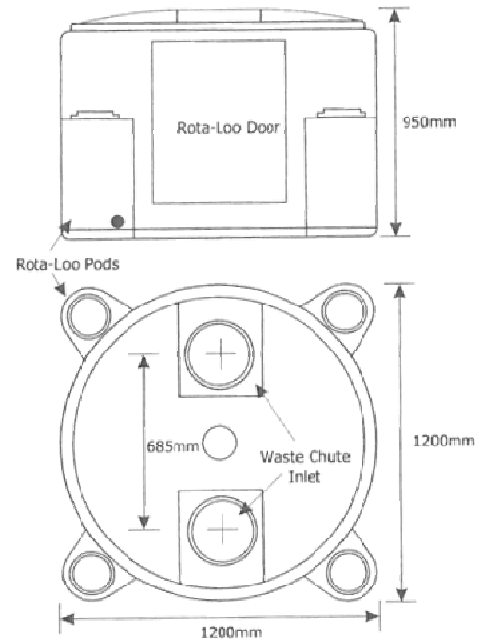

The above dimensions are for the Rota-Loo only and they do not include any Air Inlet, Vent Pipe or Waste Chute connections.

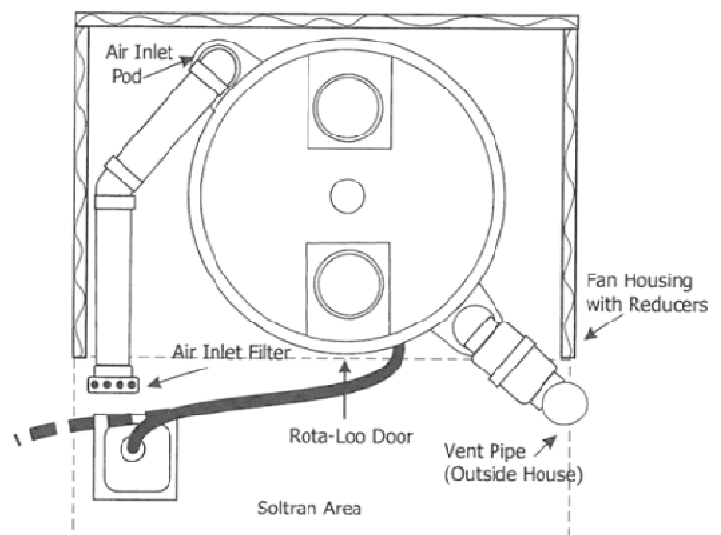

Allow also sufficient space to permit fitting insulation around the Rota-Loo. This is essential in cold climates.

Location and Building Considerations

Maximising Heat

Do not underestimate the importance of acquiring and maintaining heat in the Rota-Loo. The heat is used to increase composting efficiency, help evaporate liquids and kill pathogens.

Locating the Rota-Loo in a sunny location, preferably on the north side of the building (in the southern hemisphere) is worth considering and will not necessarily interrupt the energy efficiency of the building. Utilising a solar collector (Soltran module or similar) will greatly improve the efficiency of operation and in cold climates may be necessary.

As a minimum, the air inlet pipe should draw air from a warm place and be painted black (to act as a solar collector) or insulated (to stop heat being lost)

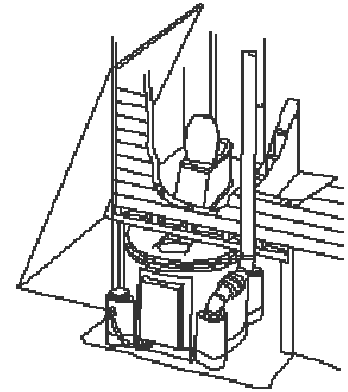

Locations where the monthly average temperature falls below 10°C for 3 months or more each year, provision must be made to use a solar collector and insulation

Toilet Pedestal and Rota-Loo

- The Rota-Loo must be located directly below the Toilet Pedestal.
- The RL950 may have 2 pedestals connected, which may be on different levels. The 2 pedestals must be at 685mm centres (see drawing pg 5 above).
- The height of the pedestal above the Rota-Loo may vary according to the building design. We recommend a minimum of 300mm from the base of the pedestal to the top of the Rota-Loo. The Waste Chute supplied allows for 800mm from the base of the Pedestal to the top of the Rota-Loo but additional Waste Chutes may be added to increase this if desired.
- Don't plan to install a light directly over the pedestal/waste chute as this will attract flying insects.

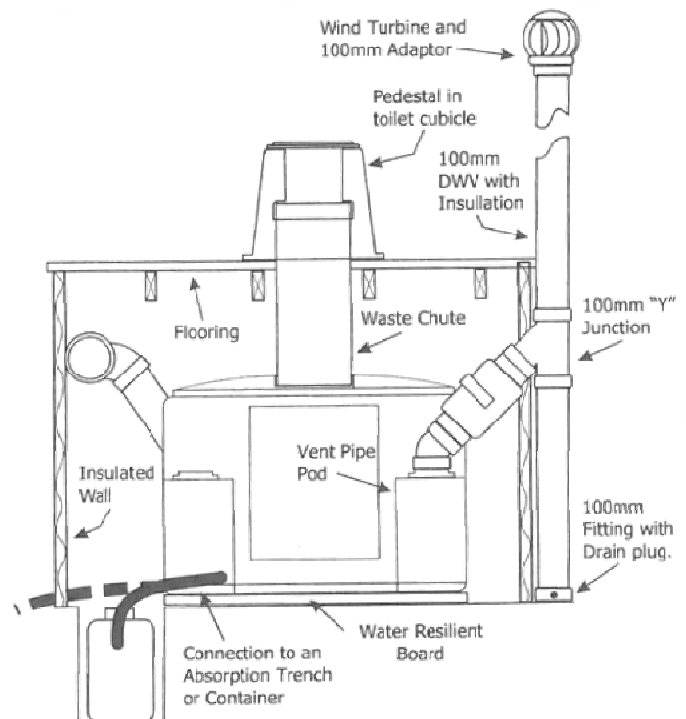

Locations where the monthly Relative Humidity exceeds 80% at any time, a vent drain and insulation of the outlet vent should be installed to ensure condensate does not re-enter the Rota-Loo.

NOTE: AS1546.2 requires that the top of the composting bin must be at least 400mm below the toilet seat. This requirement is assured with any normal Rota-Loo installation

Typically the waste chute is located directly over the bin immediately at the access door as this provides the easiest operation scenario - the waste chute cut-out in the top comes from the factory in that position. The Rota-Loo lid can be rotated so the toilet drops into another bin location. If the building design requires this, consider the impact on the operation and making sure that the active bin is always located directly under the waste chute.

Structural Issues

The Rota-Loo is installed sub-floor. It may be installed under a concrete slab or bearer and joist floor, in a full or partial cellar as desired in the building design. Consider the spacing of joists or concrete slab penetrations to allow for the waste chute. Consult a relevant Engineer to ensure support spacing and floor spans are adequate for the size and position of the Rota-Loo.

Most Rota-Loos are installed in a location largely protected from the elements and can sit freely on the base. If your installation is likely to experience extremes, you may need to consider anchoring the Rota-Loo to the ground to prevent it moving in the event of weather events. Rota-Loo is not designed to be fully immersed in water so should not be installed where severe flooding may occur without flood protection.

AS1546.2 requires that access to a WCT be prevented from unauthorised people. Consider whether your installation needs access restriction methods (like locks) to prevent young children or vandals from access.

Vent System

The Rota-Loo airflow requirement is provided by 100mm DWV piping (not supplied) from an inlet filter (supplied) to a Turbo Vent (supplied) and incorporates a continuous running fan (supplied).

- The Rota-Loo 950 comes with 4 Pods for the vent piping (see drawing pg 5 above) - only 2 will be used. The Inlet should be opposite the Outlet (e.g. Plan drawing pg 5)
- The fan is to be fitted on the outlet side. Consider how the fan will be powered (240VAC or 12VDC) and ensure the fan housing is accessible for maintenance.
- The air inlet (inlet Filter) needs to be located lower than the Pedestal, otherwise you will draw air from the toilet cubicle rather than where the air inlet is located. (To draw warm air down from ceiling cavities typically requires a second fan)
- Remember that warm air naturally rises and that sharp bends restrict airflow - designing the vent piping correctly will improve natural operation.
- Warm air holding moisture entering cold air can result in condensation. Consider insulating the outlet vent piping, or providing a condensate trap, particularly in cold climates.

If a 240VAC fan is to be installed, a standard single GPO needs to be provided close to the fan position and installed according to AS/NZS3000 & AS/NZS3820.

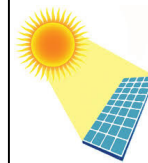

If solar power is planned, consult a solar installer to provide a system that will keep the fan running 24/7 - the 12VDC fan power consumption is 3.0W

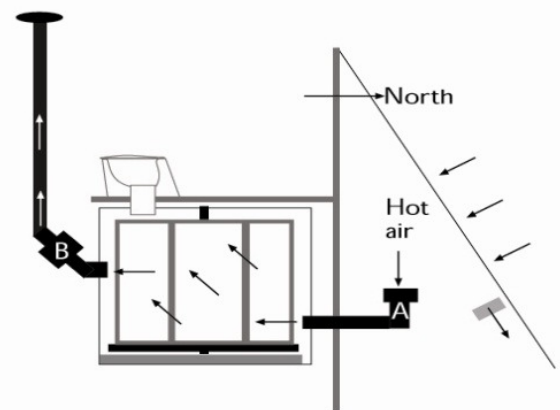

Excess Liquid

Under normal conditions, all liquids should be dealt with by normal evaporation. If the installation experiences excessive use or does not get enough heat to evaporate the liquid internally, it may be necessary to plan to install a secondary system to handle the excess liquid. This may be a secondary evaporating tank, which should be installed in a sunny location, or an Absorption Trench System. Speak to your supplier or Rota-Loo for advice if you think this may be needed.

INSTALLATION

1. Locate Rota-Loo

The first thing to do is to decide where in the toilet room you want to place the pedestal. Mark a centre position for the waste chute using the pedestal as a guide.

Reminder Notes:

The Rota-Loo 950 is normally installed with only one pedestal but may have 2 pedestals installed either at the same level or different drop heights - See drawing on page 5 for dimensions.

Be careful not to install a toilet light directly above the pedestal.

The floor joists will need to be clear of the waste chute and provision should be made to secure the waste chute to the floor joists or another part of the building structure.

Once you have found the right spot in the toilet room, draw a 260mm circle and drill a small hole through the centre point and through the floor. Go to where the Rota-Loo is to be located.

Attach a plumb bob through the centre point hole to line up the centre of the Rota-Loo waste chute hole to locate the position of the Rota-Loo.

Consider the position and ensure there is enough room around the Rota-Loo to fix the vent piping and fan and there is at least 1m in front of the door to access the bins. Note also:

- By maximising the length of the Waste Chute you will give yourself room to install the Waste Chute as well as minimise the visual impact when you happen to look down the Pedestal.
- Check you have clearance in the joists for the waste chute to pass through the floor.
- You also need enough space above the Rota-Loo so that you do not hit your head on the flooring joists when you service the unit.
- We have already pre-cut one waste chute hole in the lid of the Rota-Loo, if this location does not suit your application you can undo the self tapers and rotate the lid into the preferred location, ensure that you line the waste chute hole in the centre of the bin inside the Rota-Loo. Also remember that when you eventually rotate the bins you will need to line the bin up from the access door. When the desired position is found fix the lid down using at least 8 off screws.
- Determine which of the Vent Pods will be used (*Remember the Fan goes on the outlet side, so make sure the Outlet Pod allows easy access for Fan maintenance*)

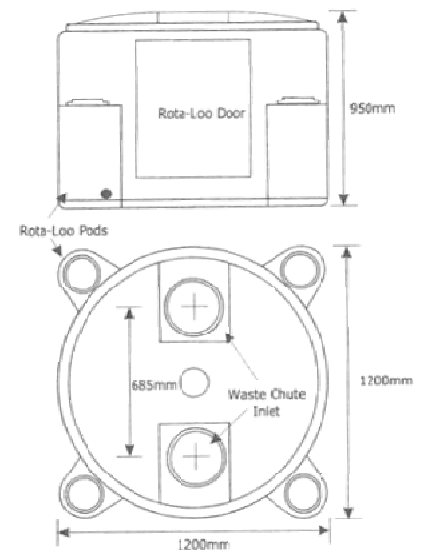

The above dimensions are for the Rota-Loo only and they do not include any Air Inlet, Vent Pipe or Waste Chute connections.

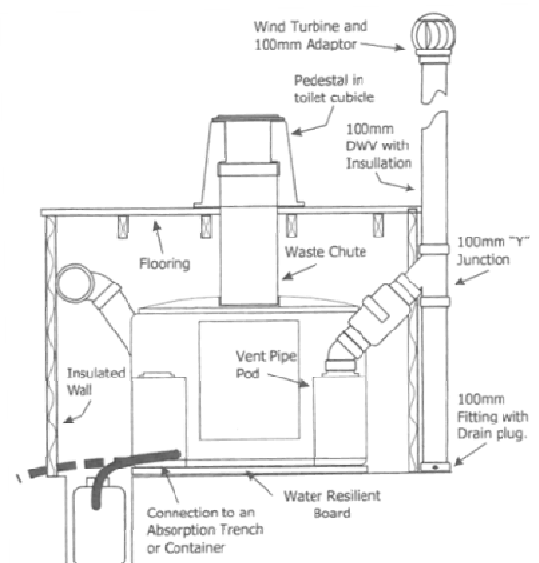

Don't cut out the Waste Chute hole in the floor until you are sure you have everything lined up in case you need to adjust the position.

2. Prepare Floor

When you have confirmed the desired location in the toilet room and right location for the Rota-Loo:

- Cut the marked 260mm circle with a jigsaw to create the Waste Chute opening.
- Prepare a firm base for the Rota-Loo to sit on. The base needs to be level, flat, firm, dry and free draining. It may be made from concrete, compressed sand or gravel or similar. Make sure there are no protruding lumps or bumps.
- Place a water resilient board on the base for the Rota-Loo to sit on. This will provide a flat surface as well as some insulation to maintain heat in the Rota-Loo.

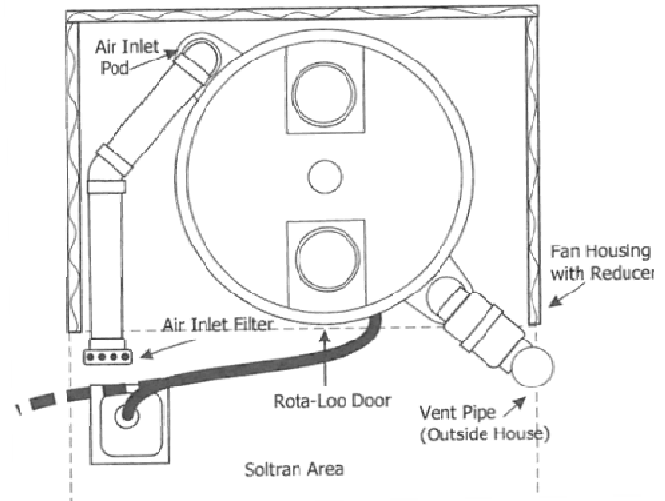

3. Locate the Rota-Loo in its Final Position

Cut holes in the desired Vent Pods (111mm Hole saw is ideal) and clean out the swarf (*See Section 4 below*).

- Slide the Rota-Loo into place.
- Fit the Waste Chute through the hole in the floor above and ensure it is vertical - use a level or plumb bob - the eye sometimes plays tricks! (SEE ALSO SECTION 7 below)
- Adjust the position of the Rota-Loo as required, making sure that it is in the best rotation for access to the bins - make sure the bin is central in the access door when the waste chute is directly over the bin. This is particularly important if the active bin is not the one at the door and you may need to mark the turntable to ensure you are always able to line up the bins correctly.
- If your installation needs the Rota-Loo to be anchored to the ground to protect it from movement due to minor floods or storms, now is the time to do this.

4. Install the Air Vent Piping

The RL950 has 4 vent pods moulded in to the main body. Two of these will be used for the air vent inlet and outlet, which need to be located diagonally opposite each other. Choose which pods to use and cut holes in the tops to take the 100mm DWV pipe connectors (111mm is the ideal size hole). The Fan is to be located close to the outlet pod so take care to choose the pod that enables free access the fan for any maintenance or inspections required.

- Air Inlet - the vent kit includes a 300mm long Pod Connector, which is to be used for the Air inlet (see Figure 1, page 5). The Pod Connector, when it's position is finalised, should be fixed to the pod using screws and sealed with Sikaflex
- Air Outlet - the vent kit includes a 100mm DWV F-M 45° elbow, which is to be used for the Air Outlet (see Figure 1, page 5). The Pod Connector, when it's position is finalised, should be fixed to the pod using screws and sealed with Sikaflex

The Air inlet

The Air Vent Outlet Pod Connector is a 45° PVC bend with a 300mm length of pipe attached to ensure the inlet air is directed to the bottom of the Rota-Loo.

Fit the Air Inlet piping using 100DWW PVC pipe and fittings with the following considerations:

- The air inlet should be connected to a warm area (see Page 7).
- Air does not like going around sharp corners.
- Hot air naturally rises.
- Wrapping the pipes in insulation will help in maintaining air temperatures.
- The greater the distance warm air travels the cooler it becomes. We have moved warm air 5m in an insulated 100mm PVC pipe and the heat drop was approximately 5 degrees.
- Always do a dry run first before finally joining the items together with plumbers glue.
- **Fit the Air Inlet Filter (provided in the kit) to the Inlet pipe - this is to prevent flying bugs entering the Rota-Loo.**
- Fit the Pipework to the Pod using 3x Self Tapping Screws and seal with Sikaflex.

The Air Outlet and Fan

The Air Vent Outlet Pod Connector is a 100mm DWV M-F 45° PVC bend.

The vent pipe can be installed either through the inside of the house or on the outside. Any exposed vent pipe should be insulated to ensure that the evaporating liquid does not condense and run back into the system. If pipe is situated in such a way (or in cold climates) that condensation may occur, it is recommended that a Y-connection is fitted to allow condensation to drain away from the fan (See diagram pg10).

The vent pipe should also be as straight as possible after leaving the Fan Housing.

The Fan Housing should be easily accessible and secured to the pipe by way of four (4) self tapping screws and placed on a 45° angle as close to the pod sleeve as possible. Make sure it is put in a place that enables access to the fan through the fan cover hatch. The Fan Housing is secured to the PVC pipe using screws and sealed with Sikaflex.

The fan assembly should be placed on a 45° angle using the 45° bend coming from the Pod, this will ensure that any condensing vapour does not adversely affect the operation of the fan. It is not recommended that the Fan Assembly be vertically, since condensation can drip down the vent pipe and cause problems including shorting out the fan and affecting your household electrics

To Ensure that your installation is Noise Free it is important to make sure that the vent pipe is insulated against causing vibrations to any surface with which it may have contact. Areas that may cause vibration noise are the vent pipe being in contact with floor, walls, joins etc. If "stand off " brackets are used on the outside of the building ensure that foam strip or a similar material is used to absorb any vibration.



The Wind Turbine Vent

The Wind Turbine Vent is manufactured with a 150mm fitting and comes with an adaptor which is supplied with the kit. These adaptors allow you to fit the 150mm fitting to 100mm PVC pipe. Use self-tapers to attach the adaptors to the Wind Turbine Vent. Slide the adaptor over the 100mm PVC Vent pipe and position, ensure the Turbine spins freely and attach using three(3) self tappers. **Do Not Use Glue.**

5. Fan Electrical Connection

Mains Powered - 240VAC Fan



A single GPO needs to be installed by and electrician to the relevant electrical standards in close proximity to the fan housing.

The fan is supplied with a lead ready to be plugged into the GPO

Solar Powered - 12VDC Fan (or 24VDC if specified)



The 12VDC fan comes with bared wires ready to connect to the 12V power supply (controller). This must be done in accordance with the instructions of the supplier of the solar power system.

It is important to check the fan rotation to ensure it provides air flow in the correct direction.

6. Insulation

Once everything is in place, the Rota-Loo should be well insulated, so that the temperature inside the unit remains as warm as possible. This is particularly important in cold climate areas.

7. Waste Chute and Pedestal

Prepare the Waste Chute

- The standard waste chute is approximately 900mm long, which includes a 100mm joining flange. This flange is **only** used to join two Standard Waste Chutes together, if this flange is not to be used, it will need to be removed since it will hinder connection to the pedestal and the Rota-Loo.
- The waste chute should fit neatly onto the lip of the Rota-Loo lid; trim off any internal ledges, otherwise waste and liquid will accumulate on them.
- Place the Waste Chute into its location on the Rota-Loo lid and through the floor.
- Ensure the ends of the waste chute are level; slide the waste chute through the hole in the floor (Make sure the flange on the waste chute has been removed if not being used). The waste chute will rest on the lip located in the Rota-Loo lid waste chute hole. Use a level and ensure that the waste chute is vertical.
- Determine the height required above the floor to fit into the chosen pedestal correctly (make sure you are allowing for any floor finish you may put in later).
- Cut the Waste Chute to the correct length ensuring the cut is square.
- Relocate the waste chute and pedestal this should give you a snug fit, it is important to check that no pressure is placed on the Rota-Loo lid, when the pedestal is sat on. You can check

It is most important to ensure the cuts made to the waste chute are square

this by asking someone to sit on the pedestal and with the door removed on the Rota-Loo to see if there is any bowing in the lid around the waste chute entry. Make any adjustments required

- When the Rota-Loo has been finally installed you will need to attach the waste chute to the joists or another part of the building structure using hoop iron, strapping or similar. The chute should not be allowed to be supported only by the top of the Rota-Loo. Do not puncture the insides of the waste chute when finally attaching the chute to the joists.

Attach Waste Chute to Rota-Loo

- Use plenty of Sikaflex around the top of the Rota-Loo to join the waste chute, also use Sikaflex to fill any gaps between the side of the waste chute and the floor, also check the waste chute is still vertical.
- Place the pedestal on the waste chute, position and using the appropriate screws fix the pedestal to the floor.
- Remove the Rota-Loo door and inside the waste chute, remove/smooth any excess Sikaflex from where the waste chute connects to the Rota-Loo.

8. Final Checks

Once all is done, the Rota-Loo is ready to use.

- Check that the turntable rotates freely
- Place a Geotextile filter into the base of each bin. Do this by taking the bin out, pushing the filter pad down to the base and replacing the bin.
- Make sure Bin No 1 is directly under the waste chute and close the door.
- Check the fan operates when turned on.

We recommend leaving the Rota-Loo for 24 hours to allow the Sikaflex to fully cure before use.

**IF YOU HAVE ANY DOUBTS OR QUERIES ABOUT YOUR INSTALLATION OR MAINTENANCE
PLEASE CONTACT YOUR SUPPLIER OR Kiel Industries Pty Ltd**

APPENDIX

CHECKLIST

A copy of our Batch Release/Packing List will be attached to the Rota-Loo. Please check that all the products you ordered have arrived. If any items are missing or any items damaged please contact the supplier or Kiel Industries immediately.

Claims for shortages or damages must be made within seven days of receipt of goods.

NON COMPLYING COMPONENTARY WILL INVALIDATE YOUR WARRANTY.

Kit Parts List

Part	Description	Qty
1	RL950 Chamber	1
2	RL950 Turntable	1
3	RL950 Access Door	1
4	RL650/950 Lid	1
5	RL950 Bin (Bucket)	6
6	RL650/950 Filter Pack of 6 filters	1
7	Air Inlet Filter	1
8	Inlet Pod Connector (300mm long)	1
9	Outlet Pod Connector (100mm long)	1
10	Fan Housing and Fan	1
11	Waste Chute	1
12	Wind Turbine Sewer Vent	1
13	Wind Turbine Adaptor	1
14	1L Bottle Biostimulant	1
15	RL950 Document Pack	1



Options any optional items ordered will be shown on the Batch Release/Packing List

Items and Materials not Supplied

Other items needed not supplied with the Rota-Loo kit:

- Sand/crushed rock for level base and water proof board or similar to place the Rota-Loo on.
- PVC piping needed to build the air vent system - 100mm DWV pipe and 45° elbows to suit
- Pipe brackets as required to secure vent piping and PVC Pipe Glue and Priming Fluid
- Sikaflex 221 for sealing the waste chute (silicone tends to go brittle after a time)
- Material to attach the waste chute to flooring joists (hoop iron or similar)
- Power source for the fan

If additional screws are required, use Stainless Steel only - (8g x 20 or 8g x 25 SS304 screws)

Optional Materials

- Insulation for the Rota-Loo and/or vent piping
- Paint for DWV pipe-work (black to absorb heat or coloured for desired finish)

GENERAL TOOLS GUIDE

- Phillips Head Screwdrivers or Phillip's head drill bit
- Saws to cut the waste chute and PVC piping
- Drills including a hole saw (111mm ideal) to cut the Vent Pods to fit the Pod Connectors.
- Measuring Equipment - Level, Plumb bob, Tape measure, ruler, roofing square
- Markers, a white marker is useful when dealing with the waste chute
- Hammer
- Caulking gun